

Алматы (7273)495-231
Ангарск (3955)60-70-56
Архангельск (8182)63-90-72
Астрахань (8512)99-46-04
Барнаул (3852)73-04-60
Белгород (4722)40-23-64
Благовещенск (4162)22-76-07
Брянск (4832)59-03-52
Владивосток (423)249-28-31
Владикавказ (8672)28-90-48
Владимир (4922)49-43-18
Волгоград (844)278-03-48
Вологда (8172)26-41-59
Воронеж (473)204-51-73
Екатеринбург (343)384-55-89
Иваново (4932)77-34-06
Ижевск (3412)26-03-58
Иркутск (395)279-98-46
Казань (843)206-01-48

Калининград (4012)72-03-81
Калуга (4842)92-23-67
Кемерово (3842)65-04-62
Киров (8332)68-02-04
Коломна (4966)23-41-49
Кострома (4942)77-07-48
Краснодар (861)203-40-90
Красноярск (391)204-63-61
Курган (3522)50-90-47
Курск (4712)77-13-04
Липецк (4742)52-20-81
Магнитогорск (3519)55-03-13
Москва (495)268-04-70
Мурманск (8152)59-64-93
Набережные Челны (8552)20-53-41
Нижний Новгород (831)429-08-12
Новокузнецк (3843)20-46-81
Новосибирск (383)227-86-73
Ноябрьск (3496)41-32-12

Омск (3812)21-46-40
Орел (4862)44-53-42
Оренбург (3532)37-68-04
Пенза (8412)22-31-16
Пермь (342)205-81-47
Петрозаводск (8142)55-98-37
Псков (8112)59-10-37
Ростов-на-Дону (863)308-18-15
Рязань (4912)46-61-64
Самара (846)206-03-16
Санкт-Петербург (812)309-46-40
Саранск (8342)22-96-24
Саратов (845)249-38-78
Севастополь (8692)22-31-93
Симферополь (3652)67-13-56
Смоленск (4812)29-41-54
Сочи (862)225-72-31
Ставрополь (8652)20-65-13
Сургут (3462)77-98-35

Сыктывкар (8212)25-95-17
Тамбов (4752)50-40-97
Тверь (4822)63-31-35
Тольятти (8482)63-91-07
Томск (3822)98-41-53
Тула (4872)33-79-87
Тюмень (3452)66-21-18
Улан-Удэ (3012)59-97-51
Ульяновск (8422)24-23-59
Уфа (347)229-48-12
Хабаровск (4212)92-98-04
Чебоксары (8352)28-53-07
Челябинск (351)202-03-61
Череповец (8202)49-02-64
Чита (3022)38-34-83
Якутск (4112)23-90-97
Ярославль (4852)69-52-93

Россия +7(495)268-04-70

Казахстан +7(7172)727-132

Киргизия +996(312)96-26-47

<https://tecfluid.nt-rt.ru> || tdf@nt-rt.ru

Датчики и трансмиттеры уровня жидкостей серии LS

 **tecfluid**

Level gauges Series LS

Level indicator, switch and transmitter for liquids

- Simple construction
- Resistant under extreme temperature and pressure conditions
- No risk of leakage
- Measuring range: from 150 mm to 15 m
- Accuracy: ± 4 mm measured value
- Connections:
 - EN 1092-1 or ANSI flanges. Other flange standards on request (JIS,...)
 - BSP or NPT threaded connections
- Materials: EN 1.4404 (AISI 316L). Others on request
- Local indication:
 - By means of external float in a glass tube
 - By means of magnetic strips
- Options:
 - Switches
 - Electronic transmitter with 4-20 mA analog output for safe or hazardous area (Ex ia IIC T6 protection, ATEX certified). HART, PROFIBUS, FIELDBUS protocols available on request, also in Ex ia versions



Working principle

A float connected to a guide tube with an internal magnet assembly on its side moves along a chamber, changing its height according to the level of a liquid inside a tank.

The float is designed for the specific working liquid density. The internal magnet assembly couples with an external float or with a magnetic strips rail mounted externally and isolated of the level gauge chamber, providing an indirect tank level indication. It can also activate the electronic accessories that are optionally supplied together with the level gauge.

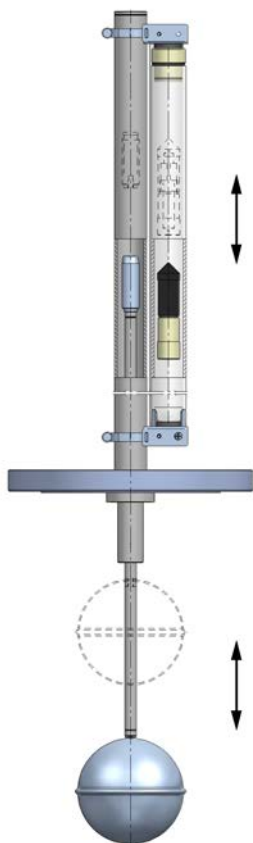

Applications

- Chemical and petrochemical industries
- Process industry
- Thermal plants and cryogenic installations
- Storage installations

Models

- **LS.../** : indication by means of external float in a borosilicate glass tube. Graduated scale in cm included. Maximum liquid temperature for AISI 316L versions: 400°C
- **LSL.../** : indication by means of bi-color magnetic strips (red-white) mounted in an anodized aluminium rail with polycarbonate cover. Optional graduated scale in cm. Maximum liquid temperature for AISI 316L versions: 250°C

- **LS20** glass tube indication, flanged connection
- **LSL20** magnetic strips indication, flanged connection
- **LS21** glass tube indication, threaded connection
- **LSL21** magnetic strips indication, threaded connection

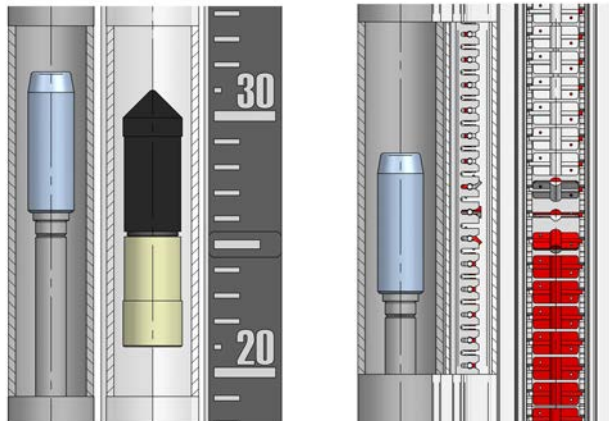

Technical data

- **Accuracy:** ± 4 mm measured value
- **Scale in cm** for LS models. For LSL models, scale in cm available on request
- **Liquid density:** 0.55 ... 2 kg/l (others on request)
- **Measuring range:** 150 mm ... 15 m
- **Liquid temperature:**
 - LSL20 ... 21: -20°C ... 250°C
 - LS20 ... 21: -20°C ... 400°C, depending on config.
- **Working pressure:** PN16 for AISI 316L models
- **Connections:**
 - EN 1092-1 or ANSI flanges. Other flange standards on request (JIS,...)
 - BSP or NPT threaded connections
- **Mounting:** on top of the tank
- **Special design** with guided float for rod longer than 2000 mm and mechanical protection in case of waves inside the tank

Limit switches and transmitters

- **LT ... LTL-APR:** adjustable reed switches
- **LT ... LTL-AAR:** adjustable reed switches (high temperature version)
- **LT ... LTL-AMM:** adjustable micro-switches
- **LT ... LTL-AMD:** adjustable inductive switches (+ relays on request)
- **LTE:** Resistive sensor transmitter. 4-20 mA output:
 - TR3420: 24 VDC 2-wire system with compact converter, for safe area or ATEX Ex ia IIC T4 or T6 certified
 - TR2420: 24 VDC 2-wire system with compact converter and HART, PROFIBUS, FIELDBUS,... protocols and also ATEX Ex ia IIC T6 certification on request

Float types

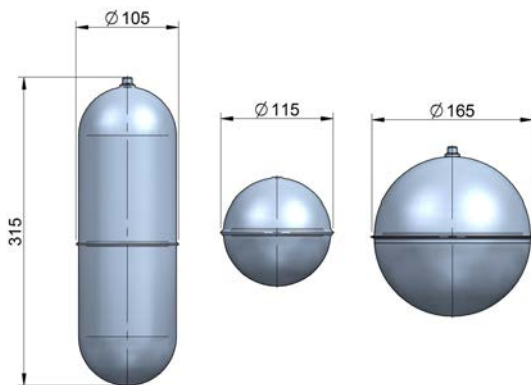

The selection of the float for each application is made according to the specific application conditions, such as liquid density and height to be measured.

The diameter of the selected float determines the minimum connection size required for the correct installation of the series LS level gauge as well.

Please consult factory.

Materials

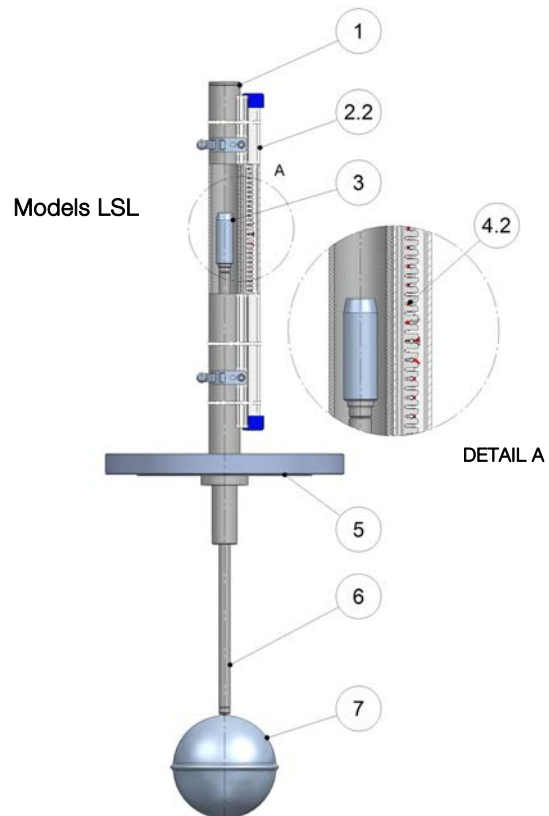
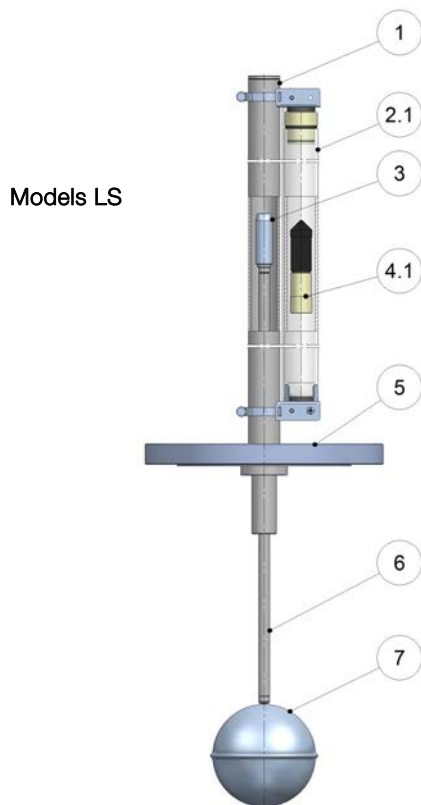

N°	Description	Models LS20 ... 21	Models LSL20 ... 21
		EN 1.4404 (AISI 316L)	EN 1.4404 (AISI 316L)
1	Body	EN 1.4404	EN 1.4404
2.1	Guide tube	Borosilicate glass	---
2.2	Mag strips rail	---	Aluminium + Polycarbonate
3	Internal magnet assembly	EN 1.4404	EN 1.4404
4.1	External float	PP / Aluminium	---
4.2	Mag strips	---	POM resin
5	Connection	EN 1.4404	EN 1.4404
6	Rod	EN 1.4404	EN 1.4404
7	Float	EN 1.4404	EN 1.4404

Dimensions

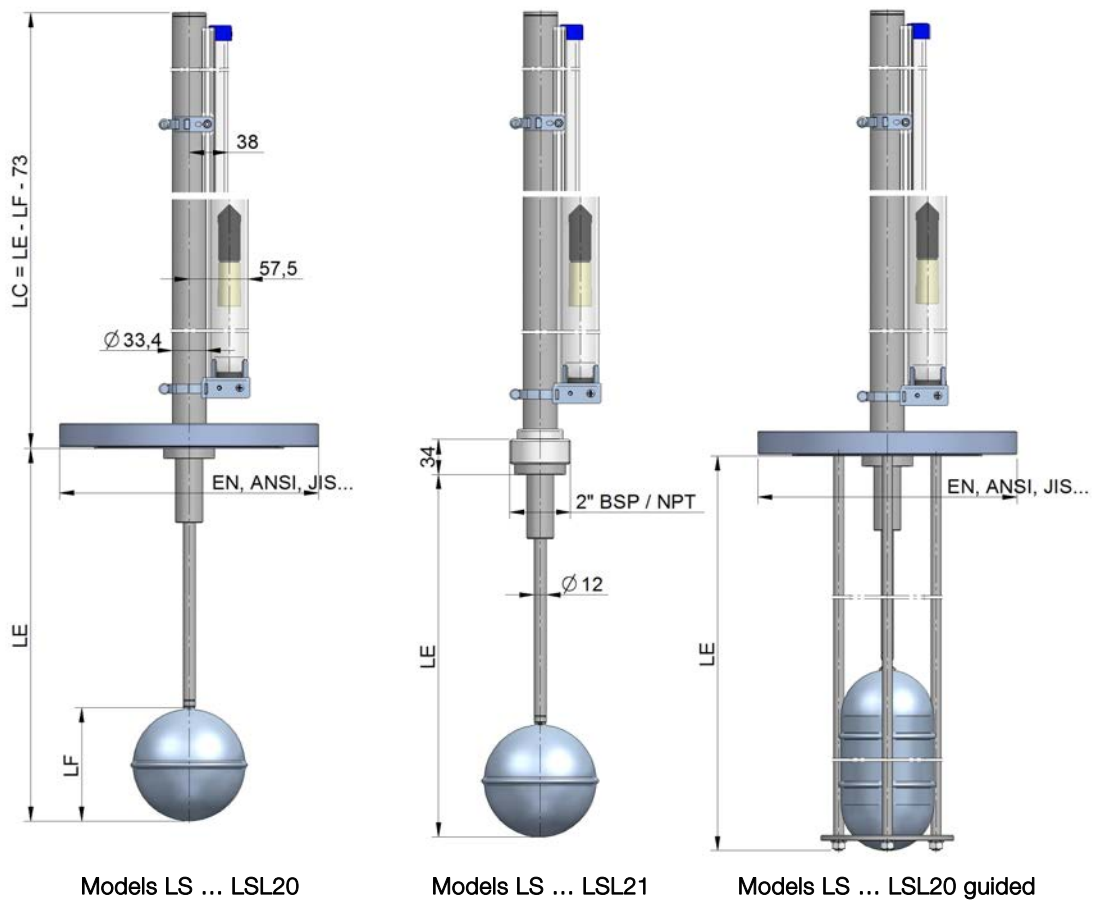

Mounting

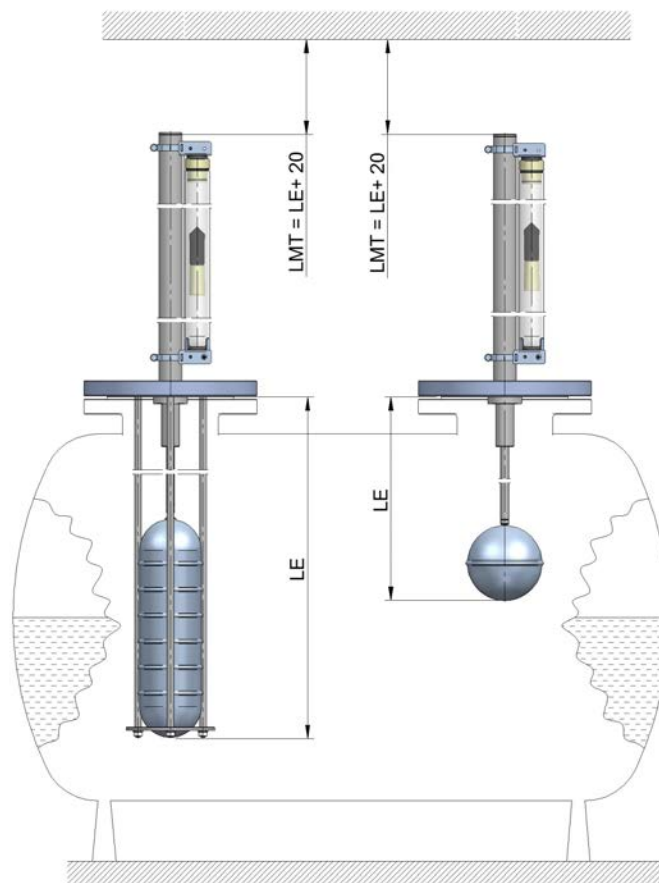

LMT: minimum distance necessary to remove the level gauge Series LS

Limit switches

Adjustable switch LT ... LTL-APR



- SPDT bi-stable reed switch
- IP65 polycarbonate housing
- Contact rating: 0.5 A 220 VAC 60 VA
- Hysteresis: ± 6 mm
- Liquid temperature: $-20^{\circ}\text{C} \dots 200^{\circ}\text{C}$
- Ambient temperature: $-10^{\circ}\text{C} \dots 70^{\circ}\text{C}$
- Suitable for hazardous area, considered as "Simple apparatus"

Adjustable switch LT ... LTL-AAR



- SPDT bi-stable reed switch
- Aluminium housing & thermal separator for high temperature
- Contact rating: 0.5 A 220 VAC 60 VA
- Hysteresis: ± 6 mm
- Liquid temperature: $-20^{\circ}\text{C} \dots 400^{\circ}\text{C}$
- Ambient temperature: $-10^{\circ}\text{C} \dots 70^{\circ}\text{C}$
- Suitable for hazardous area, considered as "Simple apparatus"

Adjustable switch LT ... LTL-AMM



- SPDT bi-stable micro-switch
- IP65 coated aluminium housing
- Contact rating: 3 A 220 VAC
- Hysteresis: ± 6 mm
- Liquid temperature: $-20^{\circ}\text{C} \dots 200^{\circ}\text{C}$
- Ambient temperature: $-25^{\circ}\text{C} \dots 80^{\circ}\text{C}$
- Mechanical life: 20×10^6 operations
- Suitable for hazardous area, considered as "Simple apparatus"

Adjustable switch LT ... LTL-AMD



NAMUR (EN 60947-5-6) 3.5 mm slot type inductive detector activated by vane, mounted in an aluminium housing.

- Power supply: 8 VDC
- Hysteresis: ± 6 mm
- Liquid temperature: $-20^{\circ}\text{C} \dots 200^{\circ}\text{C}$
- Ambient temperature: $-25^{\circ}\text{C} \dots +70^{\circ}\text{C}$
- ATEX certification Ex ia IIC T6

Control relay (on request)

NAMUR (EN 60947-5-6) for 1 or 2 inductive detectors.

- Power supply: 24 ... 253 VAC 50-60 Hz / 24 ... 300 VDC
- Input: NAMUR Ex ia IIC
- Output: 1 or 2 relay contacts
- Output rating: 2 A 250 VAC 100 VA / 1 A 24 VDC
- Ambient temperature: $-25^{\circ}\text{C} \dots +70^{\circ}\text{C}$

LT ... LTL-APR

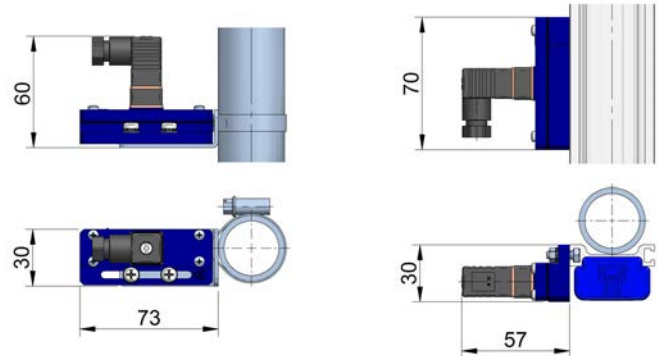

LT ... LTL-AAR

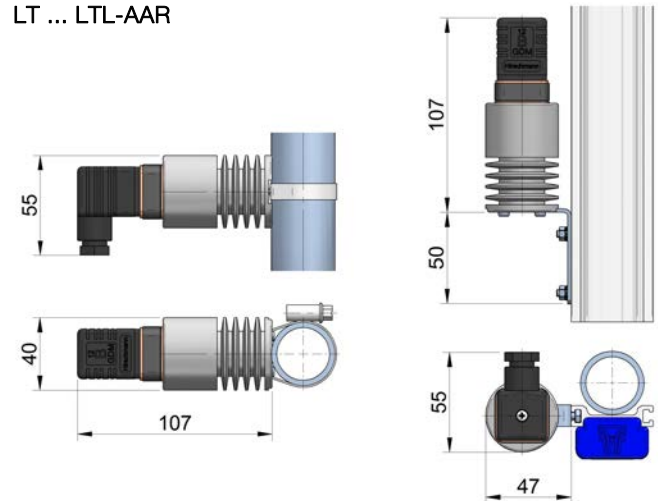

LT ... LTL-AMM / AMD

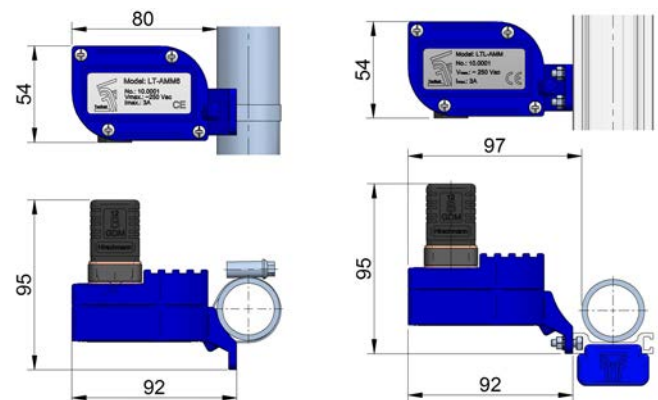

Transmitters

Transmitter LTE 4-20 mA



Transmitter composed of a resistive sensor based on a reed and resistances chain, mounted on a printed circuit placed inside a guide tube. Not wetted by the process liquid.

Variations in level inside the tank move the internal magnet assembly of the LS or LSL indicator, which by means of magnetic coupling changes the value of the resistance of the resistive sensor in correspondence to the measured liquid level.

These variations of resistance are processed by an electronic converter in order to obtain a 4-20 mA current output proportional to liquid level.

Technical data LTE

- Connection by means of IP65 connector, IP67 polycarbonate housing or IP67 aluminium housing
- Distance between reed switches: 10 mm
- Liquid temperature: -20°C ... 250°C
- Ambient temperature: -20°C ... 60°C

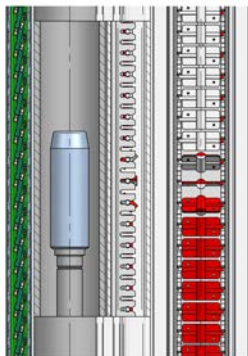

Converters series TR

- 2-wire system with 4-20 mA output
- TR3420 safe area version

- TR3420Ex hazardous area version ATEX Ex ia IIC T4 or T6
 - Power supply: 8 ... 30 VDC
- TR2420H (HART protocol), TR2420P (Profibus protocol) or TR2420F (Fieldbus protocol). Also available in combination with their Ex ia versions

Electronic converter

Model MT03L

- Electronic converter for level applications
- Resistance and current inputs
- Programmable via USB cable by means of Tecfluid S.A. Winsmeter MT03 software or by means of keyboard and graphic display with intuitive menus
- Power supply: 90 ... 265 VAC 50 / 60 Hz
 - 18 ... 36 VDC
- Full diagnosis and optional password
- Panel mounting
- Dimensions 96 x 96 mm DIN 43700
- Ingress protection: IP50 front, IP30 back (Optional IP65 front with silicone cover)
- Ambient temperature: -20°C ... +60°C
- 5 digits level indication
- Programmable 4-20 mA analog output
- 2 x relay outputs programmable as level alarms





По вопросам продаж и поддержки обращайтесь:

Алматы (7273)495-231
Ангарск (3955)60-70-56
Архангельск (8182)63-90-72
Астрахань (8512)99-46-04
Барнаул (3852)73-04-60
Белгород (4722)40-23-64
Благовещенск (4162)22-76-07
Брянск (4832)59-03-52
Владивосток (423)249-28-31
Владикавказ (8672)28-90-48
Владимир (4922)49-43-18
Волгоград (844)278-03-48
Вологда (8172)26-41-59
Воронеж (473)204-51-73
Екатеринбург (343)384-55-89
Иваново (4932)77-34-06
Ижевск (3412)26-03-58
Иркутск (395)279-98-46
Казань (843)206-01-48

Калининград (4012)72-03-81
Калуга (4842)92-23-67
Кемерово (3842)65-04-62
Киров (8332)68-02-04
Коломна (4966)23-41-49
Кострома (4942)77-07-48
Краснодар (861)203-40-90
Красноярск (391)204-63-61
Курган (3522)50-90-47
Курск (4712)77-13-04
Липецк (4742)52-20-81
Магнитогорск (3519)55-03-13
Москва (495)268-04-70
Мурманск (8152)59-64-93
Набережные Челны (8552)20-53-41
Нижний Новгород (831)429-08-12
Новокузнецк (3843)20-46-81
Новосибирск (383)227-86-73
Ноябрьск (3496)41-32-12

Омск (3812)21-46-40
Орел (4862)44-53-42
Оренбург (3532)37-68-04
Пенза (8412)22-31-16
Пермь (342)205-81-47
Петрозаводск (8142)55-98-37
Псков (8112)59-10-37
Ростов-на-Дону (863)308-18-15
Рязань (4912)46-61-64
Самара (846)206-03-16
Санкт-Петербург (812)309-46-40
Саранск (8342)22-96-24
Саратов (845)249-38-78
Севастополь (8692)22-31-93
Симферополь (3652)67-13-56
Смоленск (4812)29-41-54
Сочи (862)225-72-31
Ставрополь (8652)20-65-13
Сургут (3462)77-98-35

Сыктывкар (8212)25-95-17
Тамбов (4752)50-40-97
Тверь (4822)63-31-35
Тольятти (8482)63-91-07
Томск (3822)98-41-53
Тула (4872)33-79-87
Тюмень (3452)66-21-18
Улан-Удэ (3012)59-97-51
Ульяновск (8422)24-23-59
Уфа (347)229-48-12
Хабаровск (4212)92-98-04
Чебоксары (8352)28-53-07
Челябинск (351)202-03-61
Череповец (8202)49-02-64
Чита (3022)38-34-83
Якутск (4112)23-90-97
Ярославль (4852)69-52-93

Россия +7(495)268-04-70

Казахстан +7(7172)727-132

Киргизия +996(312)96-26-47

<https://tecfluid.nt-rt.ru> || tdf@nt-rt.ru