

Алматы (7273)495-231
Ангарск (3955)60-70-56
Архангельск (8182)63-90-72
Астрахань (8512)99-46-04
Барнаул (3852)73-04-60
Белгород (4722)40-23-64
Благовещенск (4162)22-76-07
Брянск (4832)59-03-52
Владивосток (423)249-28-31
Владикавказ (8672)28-90-48
Владимир (4922)49-43-18
Волгоград (844)278-03-48
Вологда (8172)26-41-59
Воронеж (473)204-51-73
Екатеринбург (343)384-55-89
Иваново (4932)77-34-06
Ижевск (3412)26-03-58
Иркутск (395)279-98-46
Казань (843)206-01-48

Калининград (4012)72-03-81
Калуга (4842)92-23-67
Кемерово (3842)65-04-62
Киров (8332)68-02-04
Коломна (4966)23-41-49
Кострома (4942)77-07-48
Краснодар (861)203-40-90
Красноярск (391)204-63-61
Курган (3522)50-90-47
Курск (4712)77-13-04
Липецк (4742)52-20-81
Магнитогорск (3519)55-03-13
Москва (495)268-04-70
Мурманск (8152)59-64-93
Набережные Челны (8552)20-53-41
Нижний Новгород (831)429-08-12
Новокузнецк (3843)20-46-81
Новосибирск (383)227-86-73
Ноябрьск (3496)41-32-12

Омск (3812)21-46-40
Орел (4862)44-53-42
Оренбург (3532)37-68-04
Пенза (8412)22-31-16
Пермь (342)205-81-47
Петрозаводск (8142)55-98-37
Псков (8112)59-10-37
Ростов-на-Дону (863)308-18-15
Рязань (4912)46-61-64
Самара (846)206-03-16
Санкт-Петербург (812)309-46-40
Саранск (8342)22-96-24
Саратов (845)249-38-78
Севастополь (8692)22-31-93
Симферополь (3652)67-13-56
Смоленск (4812)29-41-54
Сочи (862)225-72-31
Ставрополь (8652)20-65-13
Сургут (3462)77-98-35

Сыктывкар (8212)25-95-17
Тамбов (4752)50-40-97
Тверь (4822)63-31-35
Тольятти (8482)63-91-07
Томск (3822)98-41-53
Тула (4872)33-79-87
Тюмень (3452)66-21-18
Улан-Удэ (3012)59-97-51
Ульяновск (8422)24-23-59
Уфа (347)229-48-12
Хабаровск (4212)92-98-04
Чебоксары (8352)28-53-07
Челябинск (351)202-03-61
Череповец (8202)49-02-64
Чита (3022)38-34-83
Якутск (4112)23-90-97
Ярославль (4852)69-52-93

Россия +7(495)268-04-70

Казахстан +7(7172)727-132

Киргизия +996(312)96-26-47

<https://tecfluid.nt-rt.ru> || tdf@nt-rt.ru

Реле уровня для токопроводящих жидкостей серии DNFA, PNFA

 **tecfluid**

LEVEL AND PHASE FAULT CONTROL FOR CONDUCTIVE LIQUIDS DNFA / PNFA SERIES

Benefits

- Simple, reliable and economical
- Combined monitoring of maximum and/or minimum level and phase failure
- Sensitivity 10 to 100 KOhms
- Power: 380 3 x 380VAC
400 3 x 400VAC
415 3 x 415VAC
440 3 x 440VAC



Functioning

Maximum and minimum level control : The relay is activated when the liquid level reaches the maximum level electrode (5:PNFA; Y2:DNFA). It is deactivated when it drops below the minimum level electrode (6:PNFA; Y1:DNFA).

Maximum or minimum level control : The relay is activated when the liquid level reaches the electrode (5-6:PNFA; Y1/Y2:DNFA) and it is deactivated when it drops below the latter.

Technical data

Phase fault: At a default of one or more phases, the relay deactivates. When the fault concerns a single phase, the relay is deactivated at -20% of the nominal voltage. If it's about three phases, the relay is deactivated at -15% of the nominal voltage.

LED indication: Voltage present: Green
Relay On: Red

Sensitivity range: Adjustable from 10 to 100 KOhms

Probe voltage: 24 VAC

Probe current: 4mA (short-circuited)

Characteristics of the probe cable

Normally cables from 1 to 2.5 mm are used. 2-section with good insulation and unshielded. In some installations, when the power line and probes are parallel in the same tube and with long distances, it is recommended to use shielded cable.

The resistance between the cables and ground must be at least 200KΩ. The braid is connected to the reference (ground).

Ground connection

If the tank is not conductive, an additional probe must be installed to connect the reference (ground) to terminal 7 (PNFA) or Z1 (DNFA).

Probes and accessories: Electrodes: NS, NR 43650, NRA 43650, NR, NRA, NT, NRP, NP, NRT2.

Electrode separators: NR.SEP, NRA.SEP - Nut: NR. TUE/P, NR. TUE/T Surge

Protector: PS-310KΩ...100KΩ

Housing	Function	Exit	Tension	Range
P: Plug-in D: DIN rail	NF Control of level and phase fault	A: 1 NO	380 3 x 380VAC 400 3 x 400VAC 415 3 x 415VAC 440 3 x 440VAC	100K 10KΩ..100KΩ

Operation diagram

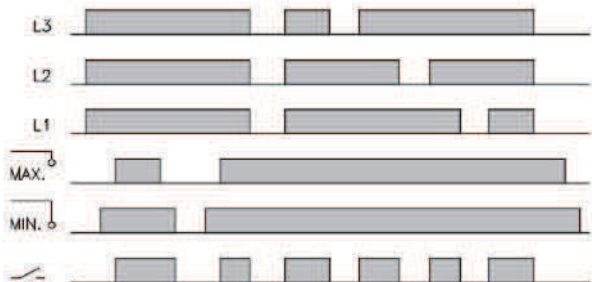

Setting

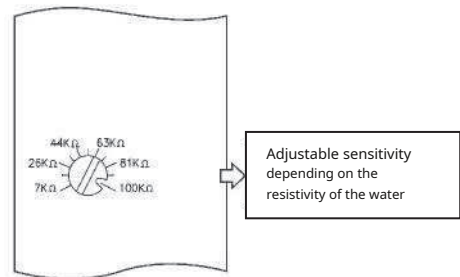

Connection diagram

PNFA

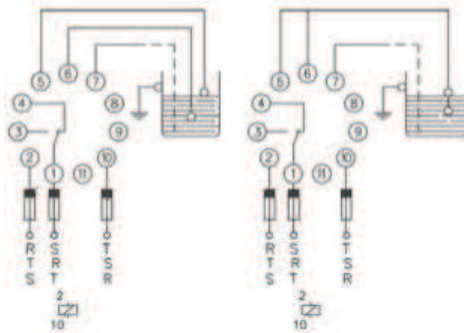

DNFA

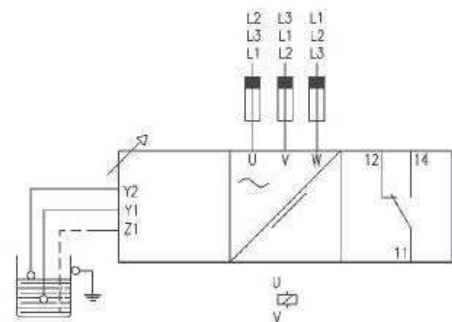

Supply voltage

	AC	
	PNFA	DNFA
Isolation galvanic	Yes	
Frequency	50/60Hz	
Margins of work	+ /-10%...-15°C	
Positive	-	
Polarity protected	-	

Output relay

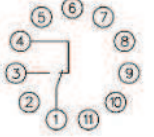
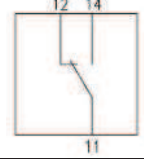
		PNFA	DNFA
			
resistive load	AC	8A / 250V	
	CC	0.25A / 200V 8A / 24V	
Inductive load	AC	2.5A / 250V	
	CC	4A / 24V	
Mechanical life		> 30x10 ⁶ operations	
Max. mechanical operation		72,000 operations / hour	
Electrical life at full load		360 operations / hour	
Contact material		Ag Ni 90/10	
Max voltage		440VAC	
Operating voltage		250VAC	
Voltage between inverters		2500VAC	
Voltage between contacts		1000VAC	
Coil/contact voltage		5000VAC	
Coil/contact distance		10mm	
Insulation resistance		> 10 ⁴ MΩ	

Technical data

	PNFA	DNFA
Neutral phase voltage	300V	
Overvoltage category	III	
Impulse voltage	4kV	
pollution degree	2	3
Degree of protection	IP 20 B	IP20
Approximate weight	250g	280g
Storage temperature	- 50...85°C	
Temp. Operating	- 20...+50°C	
Humidity	30...85% RH	
Housing	Cycloy, light gray	
Base	Lexan, gray clear	-
LED viewfinder	Lexan, Clear	
Buttons, terminals and base	Technyl, dark blue	
Basic terminal blocks	Nickel-plated brass	-
Screw terminals	-	Brass

Standards: Designed and manufactured under EEC regulations.
 Electromagnetic compatibility, directives 89/366/CEE and 92/31/CEE.
 Electrical safety, directive 73/23/CEE.
 Plastic materials: UL 91 V0

Dimensions

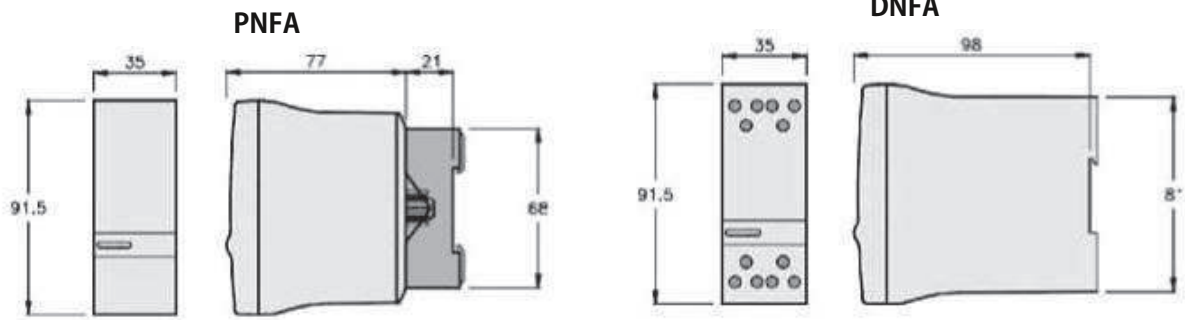

NR, NRA, NB, NRC, NTBI, NTBA, NCPR, NCVSC probes





По вопросам продаж и поддержки обращайтесь:

Алматы (7273)495-231
Ангарск (3955)60-70-56
Архангельск (8182)63-90-72
Астрахань (8512)99-46-04
Барнаул (3852)73-04-60
Белгород (4722)40-23-64
Благовещенск (4162)22-76-07
Брянск (4832)59-03-52
Владивосток (423)249-28-31
Владикавказ (8672)28-90-48
Владимир (4922)49-43-18
Волгоград (844)278-03-48
Вологда (8172)26-41-59
Воронеж (473)204-51-73
Екатеринбург (343)384-55-89
Иваново (4932)77-34-06
Ижевск (3412)26-03-58
Иркутск (395)279-98-46
Казань (843)206-01-48

Калининград (4012)72-03-81
Калуга (4842)92-23-67
Кемерово (3842)65-04-62
Киров (8332)68-02-04
Коломна (4966)23-41-49
Кострома (4942)77-07-48
Краснодар (861)203-40-90
Красноярск (391)204-63-61
Курган (3522)50-90-47
Курск (4712)77-13-04
Липецк (4742)52-20-81
Магнитогорск (3519)55-03-13
Москва (495)268-04-70
Мурманск (8152)59-64-93
Набережные Челны (8552)20-53-41
Нижний Новгород (831)429-08-12
Новокузнецк (3843)20-46-81
Новосибирск (383)227-86-73
Ноябрьск (3496)41-32-12

Омск (3812)21-46-40
Орел (4862)44-53-42
Оренбург (3532)37-68-04
Пенза (8412)22-31-16
Пермь (342)205-81-47
Петрозаводск (8142)55-98-37
Псков (8112)59-10-37
Ростов-на-Дону (863)308-18-15
Рязань (4912)46-61-64
Самара (846)206-03-16
Санкт-Петербург (812)309-46-40
Саранск (8342)22-96-24
Саратов (845)249-38-78
Севастополь (8692)22-31-93
Симферополь (3652)67-13-56
Смоленск (4812)29-41-54
Сочи (862)225-72-31
Ставрополь (8652)20-65-13
Сургут (3462)77-98-35

Сыктывкар (8212)25-95-17
Тамбов (4752)50-40-97
Тверь (4822)63-31-35
Тольятти (8482)63-91-07
Томск (3822)98-41-53
Тула (4872)33-79-87
Тюмень (3452)66-21-18
Улан-Удэ (3012)59-97-51
Ульяновск (8422)24-23-59
Уфа (347)229-48-12
Хабаровск (4212)92-98-04
Чебоксары (8352)28-53-07
Челябинск (351)202-03-61
Череповец (8202)49-02-64
Чита (3022)38-34-83
Якутск (4112)23-90-97
Ярославль (4852)69-52-93

Россия +7(495)268-04-70

Казахстан +7(7172)727-132

Киргизия +996(312)96-26-47

<https://tecfluid.nt-rt.ru> || tdf@nt-rt.ru